



ONEPWR™ TOWER CHARGING STAND FOR EMERGE CORDLESS VACUUM

USER GUIDE

MODEL NUMBER: BH35200ANZV

THIS PRODUCT IS INTENDED FOR HOUSEHOLD USE ONLY. NOT FOR COMMERCIAL USE.

IMPORTANT SAFETY INSTRUCTIONS SAVE THESE INSTRUCTIONS

When using this charger, basic precautions should always be followed, including the following:
READ ALL INSTRUCTIONS BEFORE USING THIS CHARGER

WARNING: To reduce the risk of fire, electric shock, damage or injury:

- Dry location use only.
- For use only with Hoover ONEPWR™ batteries. Charge only battery packs listed in the Compatible Battery Packs Section of this User Manual. Charging any other battery packs may create a risk of injury or fire.
- Do not use with damaged cord or plug. If charger is not working as it should, has been dropped, damaged, left outdoors, or dropped into water, contact Customer Service by calling (AUS) 1300 698 130 / (NZ) 0800 126 688.
- Do not pull or carry by cord, use cord as a handle, or pull cord around sharp edges or corners. Keep cord away from heated surfaces.
- Do not unplug by pulling on cord. To unplug, grasp the plug, not the cord.
- Do not handle plug or charger with wet hands.
- Follow all charging instructions and do not charge the battery pack outside of the temperature range specified in the charging instructions. Charging improperly or at temperatures outside of the specified range may damage the battery and increase the risk of fire.
- Do not disassemble charger. Do not modify or attempt to repair the charger. This charger has no serviceable parts.
- Follow all mounting instructions. Failure to do so could result in personal injury or property damage. Manufacturer is not responsible for damage or injury caused by incorrect installation.
- This charger is not intended to be used or cleaned by persons (including children) with reduced physical, sensory or mental capabilities, or lack of experience and knowledge, unless they have been given supervision or instruction concerning the safe use of the charger by a person legally responsible for their safety. They should be supervised whilst using the charger. Children shall not use, clean, or play with this charger, which, when not in use should be secured out or their reach.
- The power cord cannot be replaced. If the cord is damaged the charger should be scrapped.
- Do not use this charger to charge non-rechargeable batteries.
- Do not use the product if it has suffered any heavy shock or jolting, or is damaged in any other way.
- Never charge a damaged battery pack. If damaged, replace immediately.
- Do not conduct charging in a position which may become exposed to sunlight or other heat source.
- Due to the heat generated during charging, the product should not be operated on a combustible surface.
- Do not conduct charging operations in the vicinity of flammable materials. Example: Cloth, packaging thinners, paint, spray paint or aerosols, lubricant, thinners, petrol
- Protect battery contacts to avoid a short circuit caused by metallic objects which could cause a fire or explosion!

TRANSPORTING LITHIUM BATTERIES

- Transport the battery in accordance with local and national provisions and regulations.
- Follow all special requirements on packaging and labelling when transporting batteries by a third party.
- Ensure that no batteries can come in contact with other batteries or conductive materials while in transport by protecting exposed connectors with insulating, non-conductive caps or tape. Do not transport batteries that are cracked or leaking. Check with the forwarding company for further advice.

!WARNING!: RISK OF FIRE, PROPERTY DAMAGE, AND INJURY. NEVER EXPOSE YOUR BATTERY PACK OR CHARGER TO WATER, MOISTURE, OR FLUIDS, INCLUDING BUT NOT LIMITED TO CORROSIVE OR CONDUCTIVE FLUIDS, OR ALLOW FLUIDS TO FLOW INSIDE THESE ITEMS. Corrosive or conductive fluids, such as salt water, chlorine, certain industrial chemicals, and bleach or bleach containing products, etc., can cause a short circuit in the battery pack. If your battery pack is exposed to a corrosive or conductive fluid, do not attempt to use or charge the battery pack and immediately cease using the battery. Please contact Customer Service immediately by calling (AUS) 1300 698 130 / (NZ) 0800 126 688.

MAINTENANCE

- Do not disassemble charger. Do not modify or attempt to repair the charger. This charger has no serviceable parts. Contact Customer Service by calling (AUS) 1300 698 130 / (NZ) 0800 126 688.
- Do not allow the charger or batteries to become contaminated with any material which could be conductive. Example: Metal particles from grinding, cutting or machining processes.
- Remove the plug of the product from the power socket when it is not in use or when cleaning it.
- If the battery is not going to be used for a while, remove the charger plug from the power socket and take the battery off the product.

STORAGE

- Store your charger in a cool dry place between 10 and 25°C.
- It is not recommended to leave it in a vehicle during hot or cold conditions. Ensure no metal filings or swarf can fall into the vents during storage, as this may cause serious injury when it is next used.

ENVIRONMENTAL PROTECTION



- Recycle raw materials instead of disposing of as waste. The machine, accessories and packaging should be sorted for environment friendly recycling.

PRODUCT SPECIFICATIONS

MODEL	CHARGER INPUT	OUTPUT
BH35200ANZV	220-240V-50Hz 60W	18V --- 2.0A

COMPATIBLE BATTERY PACKS

MODEL	TYPE	RATED VOLTAGE	RATED CAPACITY	CELL NUMBER
F18BTP021J4	Li-Ion	18V	4.0Ah	5
BH29040ANZ	Li-Ion	18V	4.0Ah	5
BH29040ANZV	Li-Ion	18V	4.0Ah	5

KNOW YOUR PRODUCT

1	Emerge Cordless Vacuum Charging Dock
2	Spare Battery Charging Dock
3	LED Lights
4	Adaptor
5	Pole
6	Base

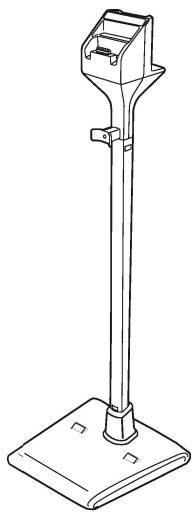
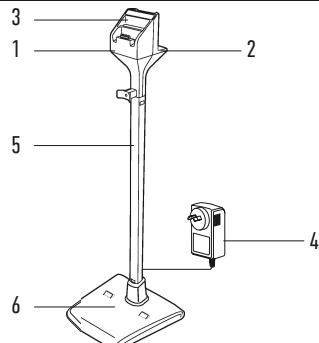

DISTRIBUTED BY:

Techtronic Industries Australia Pty Ltd
31 Gilby Road, Mount Waverley, VIC 3149, Melbourne, Australia
Customer Careline: 1300 698 130

Techtronic Industries N.Z. Limited
Unit C, 70 Business Parade South, East Tamaki, Auckland 2013,
New Zealand
Customer Careline: 0800 126 688



Efficiency Rating



Time-lag Fuse 3.15A



Regulatory Compliance Mark



For Indoor Use Only



Read User Manual



Class II Equipment

ASSEMBLY

WARNING: To prevent risk of strangulation, fire, or shock, route cord properly, avoiding loops, is out of the reach of children, and where they cannot get snagged or pulled.

WARNING: Fully assemble or install product prior to use.

1. Lay base on flat ground.
2. Insert end of pole (with single hole) into base until it clicks into place.
3. Insert charger head into top of pole until it clicks into place.
4. Attach power cord to charger head.
5. Press power cord into hidden channel down the back of pole and base.
6. Connect power supply to power outlet.
7. Slide tool accessory clips onto pole.

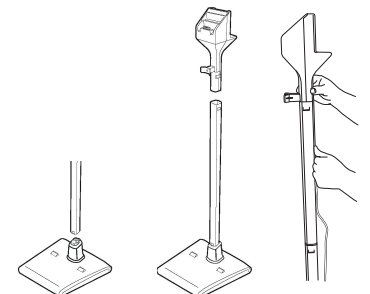

Figure 1

OPERATION

APPLICATIONS

You may use this product for the following purpose: Charging Hoover ONEPWR™ Lithium Ion Batteries.

CAUTION: When not in use, place stand on its side on a stable surface where it will not cause a tripping or falling hazard. A stand with a large battery pack will stand upright but may be easily knocked over.

CHARGING

- Charge the battery fully before first use. This will take up to 2 hours. The battery does not come fully charged.
- Make sure the power supply is normal household voltage, 220-240 volts, AC only, 50 Hz.
- Do not place the charger in an area of extreme heat or cold. It will work best at normal room temperature.
- Plug the charger into a power outlet.
- To charge the EmERGE cordless vacuum attach the battery pack to the vacuum by aligning the ribs on the battery pack to the grooves in the vacuum. Slide the battery pack into the vacuum. Place the vacuum onto the charging stand, as shown in figure 2.
- **Note:** The battery on the EmERGE will charge while docked as well as the spare on the back.
- To charge the spare battery, attach the battery pack to the rear charger by aligning the ribs on the battery pack to the grooves in the charger. Slide the battery pack into the charger.
- The battery inserted into the EmERGE cordless vacuum will charge first.
- The battery pack will become slightly warm to the touch while charging. This is normal and does not indicate a problem.
- When charging, the lights on the battery will illuminate to show the state of charge. The light on the charger will flash.
- If the light on the charger flashes red, there is an error with the battery or the charger. Try again or call customer service for support on (AUS) 1300 698 130 / (NZ) 0800 126 688.
- When the charge is complete the lights on the battery will turn off. The light on the charger will remain on.
- To remove the battery pack from the charger, press the latches and pull up on the battery pack.
- During charging, the pack and ambient temperature should be between 5 and 30°C.
- Do not charge battery in a damp or wet location. Do not use, store, or charge battery packs or products in locations where the temperature is less than 5 and more than 30°C. Do not store outside or in vehicles.
- The charger will sense if the pack, or ambient temperature, is too cold or too hot, and will return an error code (red light will remain on) and not charge the pack until ambient temperature is reached.

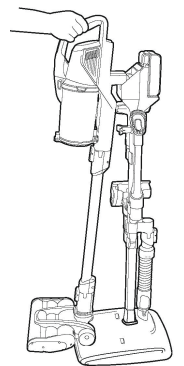

Figure 2

LED CHARGE INDICATOR

MODE	BATTERY PACK	RED LED ON CHARGER	WHITE LED ON CHARGER	ACTION NEEDED
POWER	Without Battery Pack	On for 3 seconds	On for 3 seconds	Ready to charge battery pack
TESTING	HOT Battery Pack	ON	OFF	When battery pack reaches normal temperature, charger begins charge mode
	COLD Battery Pack	ON	OFF	When battery pack reaches normal temperature, charger begins charge mode
DEFECTIVE	Defective	Flashing	OFF	Battery pack or charger is defective
<ul style="list-style-type: none"> • If defective, try to repeat the conditions a second time by removing and reinstalling the battery pack. If LED status repeats a second time, try charging a different battery. • If a different battery charges normally, dispose of the defective pack • If a different battery also indicates "Defective", the charger may be defective. 				
CHARGING	Charging – LED lights will flash depending on charge level	OFF	Flashing	Battery is being charged
FULLY CHARGED	Charged – lights will go off	OFF	LED lights will remain on	Charging is complete; charger maintains charge mode



HOOVER.COM.AU
HOOVER.CO.NZ